

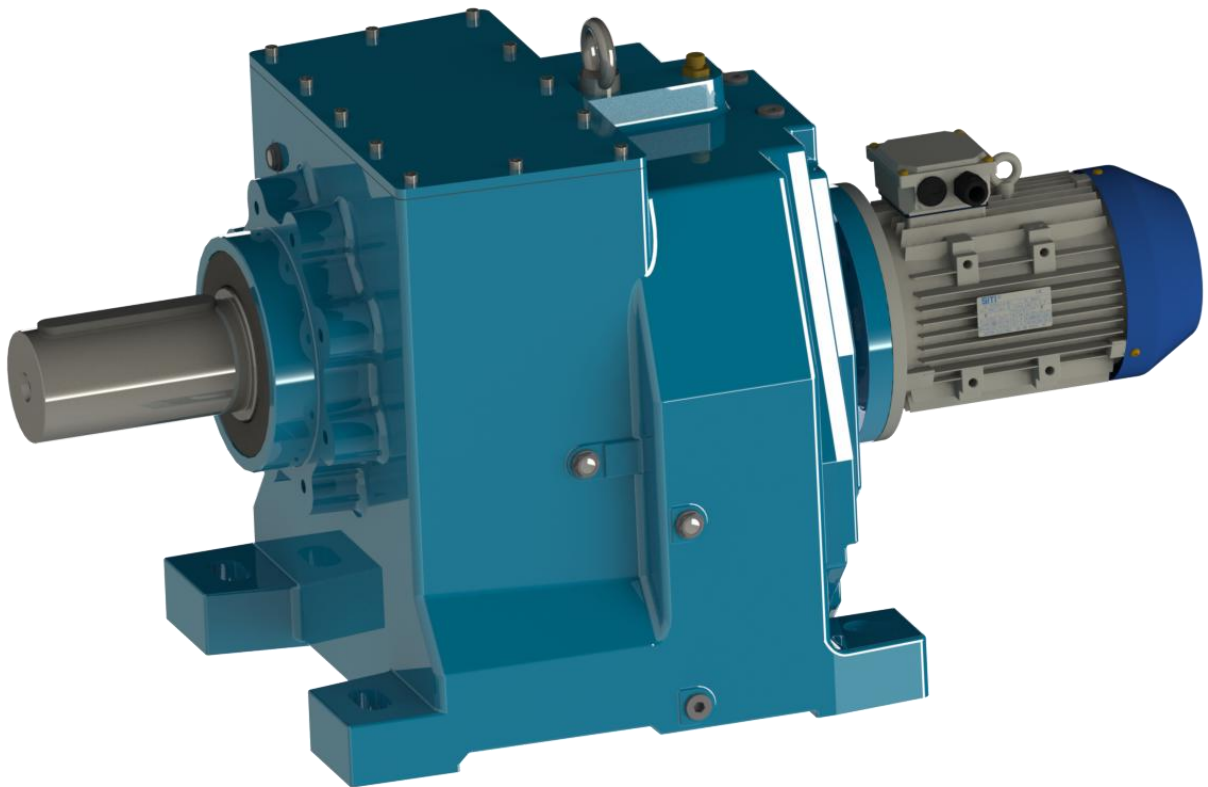

HELICAL INLINE GEARBOXES
SERIES NHL

UPGRADE



UPGRADE DESIGN NHL 100

2016

FEATURES AND PECULIARITY OF THE PRODUCT NHL – MNHL 100

Rebuilding the modularity of the product in order to minimize the number of kits for the assembly of the complete gearbox has been achieved.

The MHL range was the first SITI range which the concept of flexibility and modularity to the highest degree had been applied to, and which has been further refined in the current design review process.

These flexibility and modularity concepts, partly complementary and partly mutually associated one to the other, are the largest real strong point, which allows us to mark a major step in our favor in our comparison to all the competition.

FLEXIBILITY: With this term, in its wide sense, we mean above all the ease and speed by which a user can switch from one version to another one, in other words to change the unit into a different version, as far as the following features are concerned:

- availability in the foot-mounting or flange-mounting output version;
- changing the gear ratio;
- transforming a PAM unit to a solid input shaft version or vice-versa;
- changing the PAM size on a unit;
- adding accessory devices;
- changing a two-stage version to a three-stage unit.

Flexibility can allow all SITI distributors as well as the end users to minimize their inventory; the same SITI can take advantage of an extreme benefit.

MODULARITY: This term refers to the capacity of the gearbox to be designed and built for modules, or for functional subassemblies, which can be manufactured and assembled in the form of modular units.

In other words, the gear unit consists of several sub-groups that can be easily assembled together in different ways, to give form and substance to all existing versions.

Like the flexibility, modularity represents an extreme advantage for the whole distribution network and for SITI, too. These modules or sub-groups are usually defined kit or set.

In the redesign activity it has been further refined and optimized the concept of modularity reaching the expected purpose, i.e. to have a unique output set while ensuring a range of ratios able to cover the old SITI versions, as well the corresponding products of the main competition.

The OUTPUT KIT throughout the MNHL range, identifies the main component of the gear unit, since it comprises well over half of the components of the complete gearbox and consequently is the most expensive set. Especially for this reason SITI has set the goal of optimizing this set resulting in **only one kit**.

The output kit consists of the gearbox housing complete with already mounted output shaft, wheel, bearings and shaft seals, and with the intermediate shaft output pinion. In other words, the output kit includes all the final reduction stage, which is common to both the versions with two reduction stages and with three reduction stages

The result of this involves a huge advantage, since the already mounted output kit, alone constitutes not less than 70% of an entire gear unit, and is common to all the possible standard versions. In other words, it is always the same:

- for all the reduction ratios
- for the versions with two reduction stages and the versions in three reduction stages
- for both foot-mounting and flange-mounting versions.

INPUT KIT: MNHL100 consists of several versions. With the term “Input set” it is intended to refer to the totality of components that are located at the inlet of the motion and which allow the connection with the driving mechanism, both if it is an electric motor and an external transmission; therefore, it does not include gears and reduction stages, but only shafts, covers, bearings and other related accessories.

Specifically for the MNHL range, the versions available are the following:

- solid input shaft (in this case, units are called NHL and not MNHL); used when there is an inlet transmission, and not the direct connection with a motor.
- Hollow input shaft for traditional PAM versions; it is the classic version with hollow input shaft and input flange for direct connection (plug-in) to electric motors standardized IEC B5 or B14.

FIRST REDUCTION KIT: It consists of the first reduction gear pairs (we are considering at the moment this concept for a two-stage reduction gearbox, but we will see how well it can be extended, with no conceptual changes, to versions with three stages of reduction). Therefore, each set consists of a pinion, a wheel and one or more conversion shafts, needed to connect the input pinion to the input shaft.

INTERMEDIATE KIT (FOR ACCOMPLISHING THE THREE-STAGE VERSION): Compared to the corresponding versions with two-stage reduction, the output kit is only one, as we have previously stated above. On the other hand, it is definitely peculiar to the three-stage versions the intermediate kit, that consists in:

- a pair of helical gears, which accomplish the second (or intermediate) one of the three reduction ratios;
- two tapered roller bearings, which are the ones that sustain the intermediate shaft. In order to push the modularity at the highest level, it has been arranged that the intermediate ratio of the three-stage reduction gearbox is always the same.

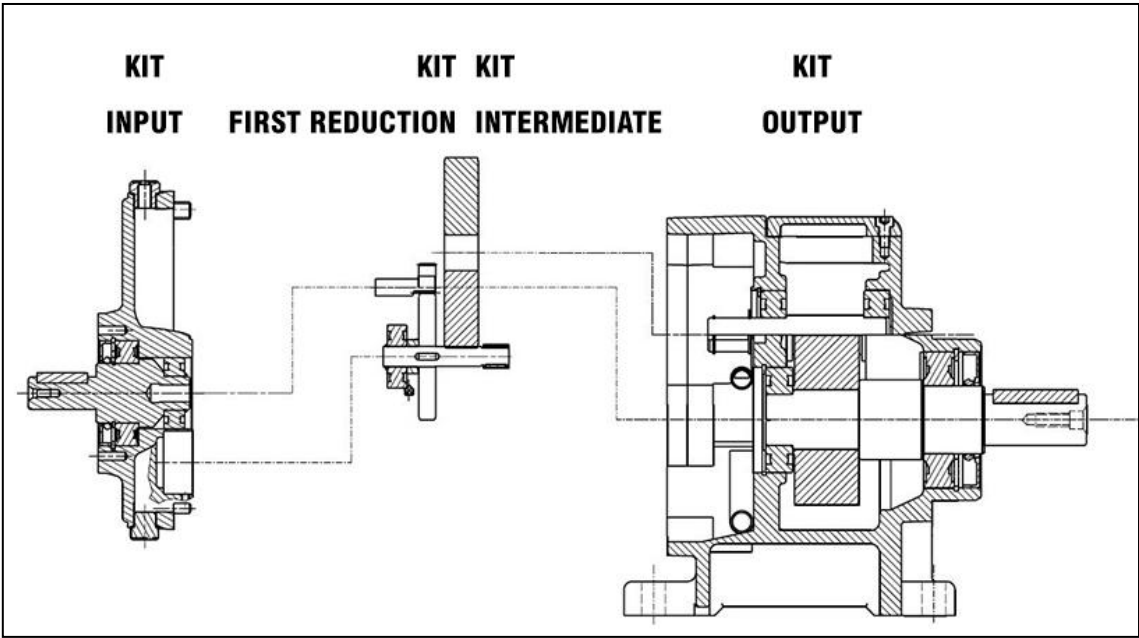
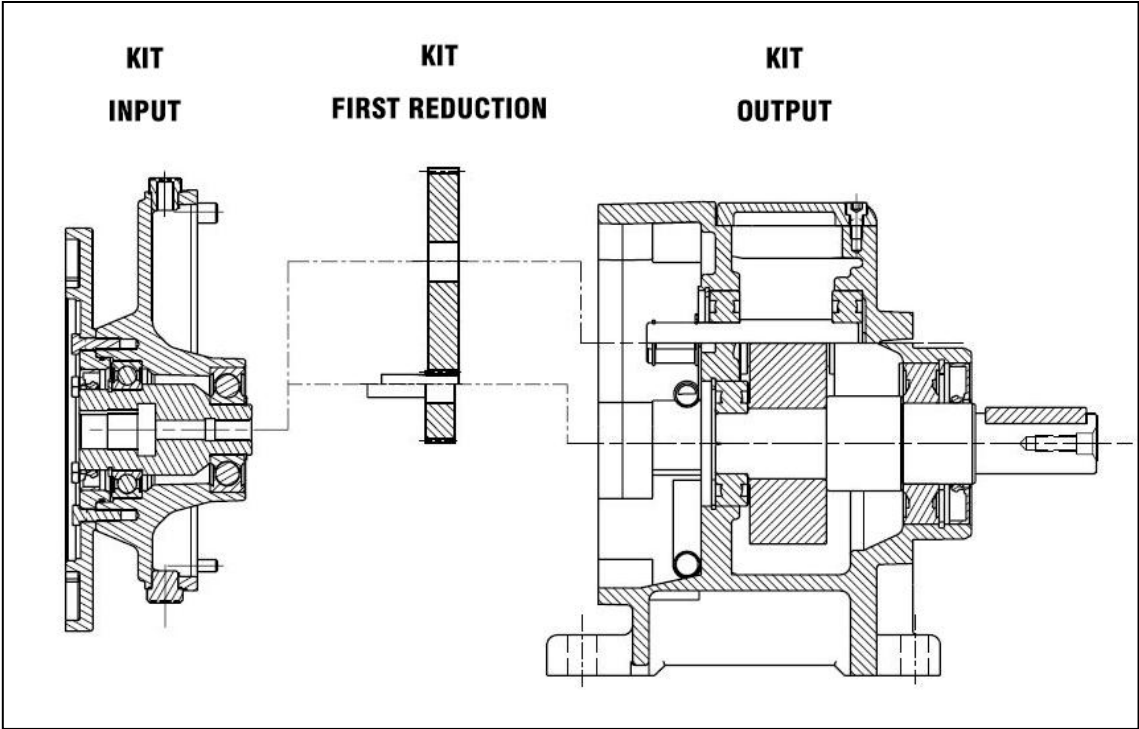

THE INTERCHANGEABILITY: In the new version even changes have been accomplished in order to make the gearbox as much interchangeable as possible with the corresponding products of the competition. The main changes include the addition of the output shaft with a diameter $\varnothing 110$ (j6), in addition to the standard $\varnothing 100$ (j6), and the height of these last ones from the mounting base to 355 mm (345mm in the old version).

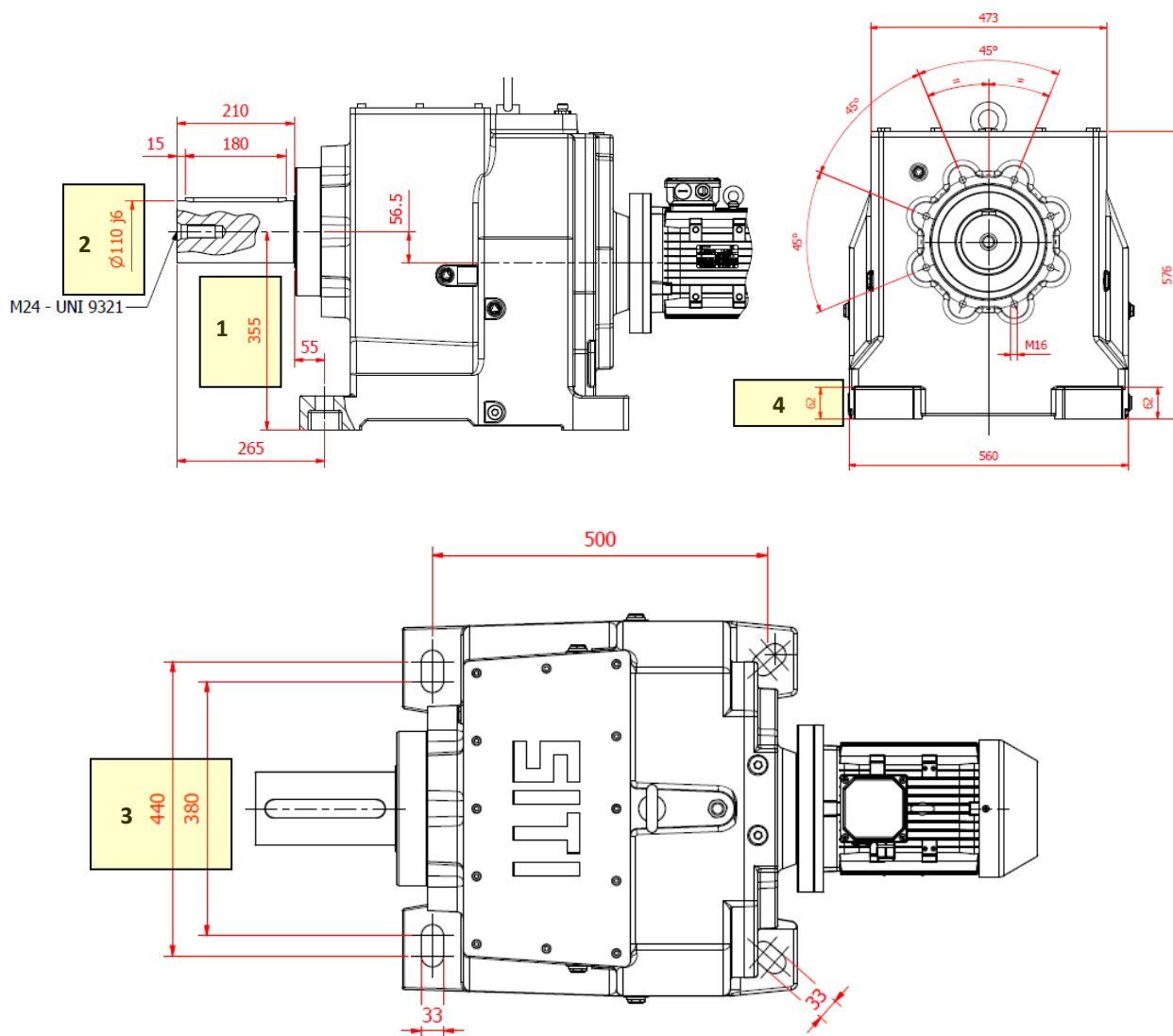

1. H355 (previous H345)
2. D.100 j6 standard - Optional D.110 j6 added in the new version
3. Added bolting pattern for center distance = 380 – it is kept even the bolting pattern for center distance=440
4. Hp=62 (previous 90)

IMPROVEMENTS

HELICAL GEARS: In the redesign of the product, a great deal of the design has focused in the optimization of the gears which have all been recalculated, optimizing the basic parameters that lead to having a high performance of the meshing, like the specific sliding, helix angles, a thicker face covering, and so forth. As a consequence of this, all machining tolerances have been optimized both in relation to tothing and to the level of center distances on the housing; in addition to this, all control processes and testing methods of the entire product line have been revised, in order to obtain a great consistency between the theoretical and practical values.

GEAR MATERIALS: All gears are made of case-hardening steel (type 20MnCr5), and are subjected to case-hardening, quenching and stress relieving heat treatments. In the review of the project it has been made a further step ahead by going to draw the output wheel from a hot forged semi-finished piece; considering the size of that gear, a forged material leads to considerable advantages:

- Greater mechanical resistance due to the arrangement of the fibers and the compacting of the material.
- Less weight because it can use smaller pieces to the same mechanical resistance.
- Elimination of internal defects due to the great compression of the material which is obtained by molding.
- Much lower distortion in the process of heat treatment, once more due to the greater compactness of the fibers, which impacts on a better quality gear. Still in reference to this point, the heat treatment process has been optimized in order to reduce to a minimum the distortions. The expectations of these improvements are to obtain a product able to give the best performance, both at the level of operating parameters, efficiency, noise, level of temperature as well as the reduction of the backlash.

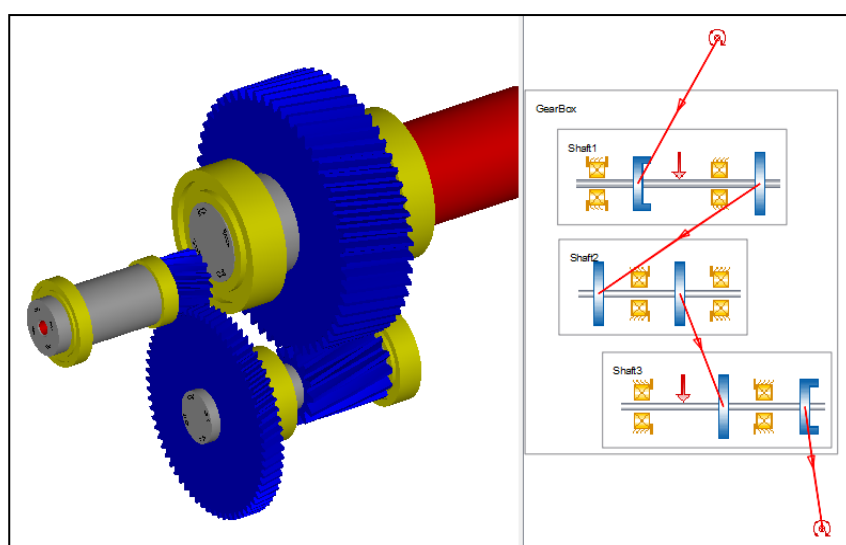

In the redesign and calculation of all the gearboxes, the latest most advanced technologies currently available on the market have been used, enabling to model the entire system and evaluate the performance of the individual components in their operating wholeness.

NEW PERFORMANCE: New performance data based on the accomplished improvements.

UPGRADE NHL 100

i	2800			1400			900			RD
	n2	M2	kW1	n2	M2	kW1	n2	M2	kW1	
2 STAGE										
5,033	556,27	10000	600,5	278,14	10500	315,3	178,80	11000	212,3	0,97
5,631	497,25	10000	536,8	248,63	10500	281,8	159,83	11000	189,8	0,97
6,314	443,47	10000	478,8	221,74	10500	251,4	142,55	11000	169,3	0,97
7,700	363,64	10000	392,6	181,82	10500	206,1	116,88	11000	138,8	0,97
9,728	287,83	10500	326,3	143,92	11000	170,9	92,52	11000	109,9	0,97
10,714	261,33	10500	296,2	130,67	11000	155,2	84,00	11000	99,8	0,97
12,179	229,91	10500	260,6	114,96	11000	136,5	73,90	11000	87,8	0,97
15,021	186,41	10500	211,3	93,20	11000	110,7	59,92	11500	74,4	0,97
16,205	172,78	10500	195,9	86,39	11000	102,6	55,54	11500	69,0	0,97
20,852	134,28	10500	152,2	67,14	11000	79,7	43,16	11500	53,6	0,97
24,881	112,54	10500	127,6	56,27	11000	66,8	36,17	11500	44,9	0,97
26,939	103,94	9500	106,6	51,97	10000	56,1	33,41	10500	37,9	0,97
29,313	95,52	8500	87,7	47,76	9000	46,4	30,70	9500	31,5	0,97
3 STAGE										
30,745	91,07	11000	109,8	45,54	12000	59,9	29,27	12000	38,5	0,955
35,911	77,97	11000	94,0	38,99	12000	51,3	25,06	12000	33,0	0,955
40,103	69,82	11000	84,2	34,91	12000	45,9	22,44	12000	29,5	0,955
47,963	58,38	11500	73,6	29,19	12000	38,4	18,76	12500	25,7	0,955
54,658	51,23	11500	64,6	25,61	12000	33,7	16,47	12500	22,6	0,955
63,028	44,42	12000	58,5	22,21	12500	30,4	14,28	12500	19,6	0,955
73,789	37,95	12000	49,9	18,97	12500	26,0	12,20	13000	17,4	0,955
80,411	34,82	12000	45,8	17,41	12500	23,9	11,19	13000	16,0	0,955
88,137	31,77	12000	41,8	15,88	12500	21,8	10,21	13000	14,6	0,955
97,267	28,79	10000	31,6	14,39	10500	16,6	9,25	11000	11,2	0,955
108,224	25,87	9000	25,5	12,94	9500	13,5	8,32	10000	9,1	0,955
121,615	23,02	8000	20,2	11,51	8500	10,7	7,40	9000	7,3	0,955

i	100/2 PAM					
	5,033			200	225	250
5,631			200	225	250	280
6,314			200	225	250	280
7,700			200	225	250	280
9,728			200	225	250	280
10,714			200	225	250	280
12,179			200	225	250	280
15,021			200	225	250	280
16,205			200	225	250	280
20,852	160	180	200	225	250	
24,881	160	180	200	225	250	
26,939	160	180	200	225	250	
29,313	160	180	200	225	250	
	100/3 PAM					
30,745		160	180	200	225	
35,911		160	180	200	225	
40,103		160	180	200	225	
47,963		160	180	200	225	
54,658		160	180	200		
63,028		160	180	200		
73,789		160	180			
80,411		160	180			
88,137		160	180			
97,267		160	180			
108,224	132	160				
121,615	132	160				

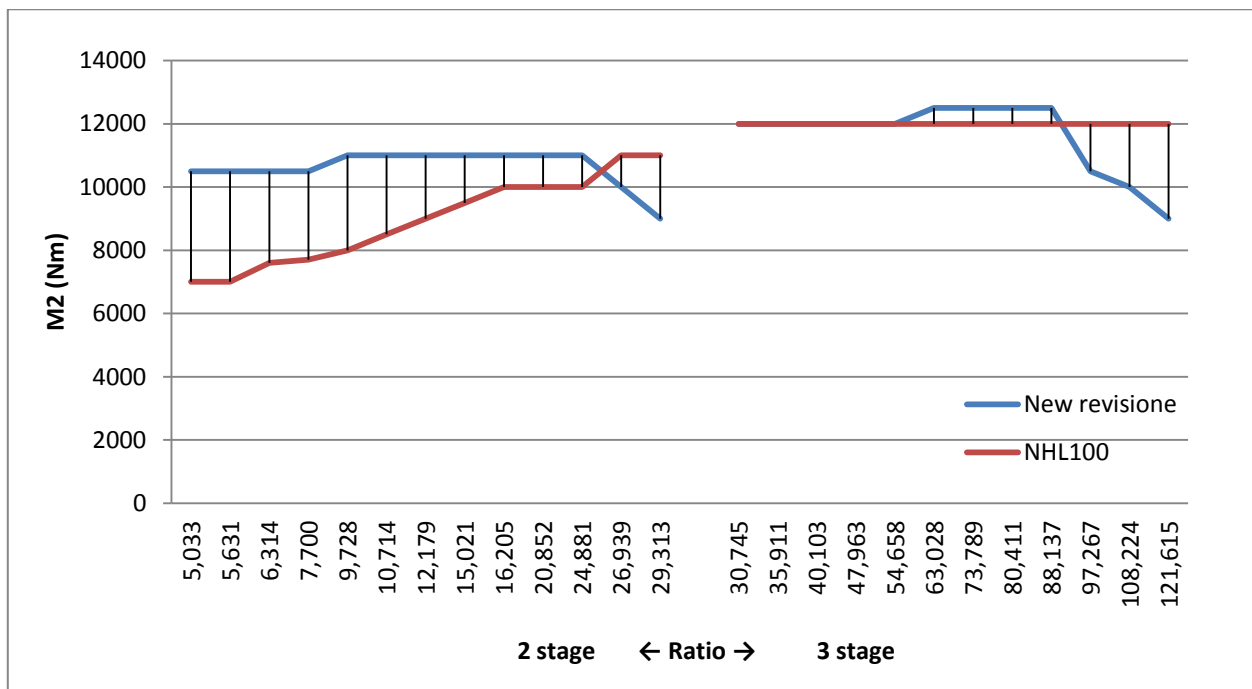

Curva continua: rotazione sinistra (Continuous curve: Counterclockwise motion)

Curva a tratti: rotazione destra (Dashed curve: Clockwise motion)

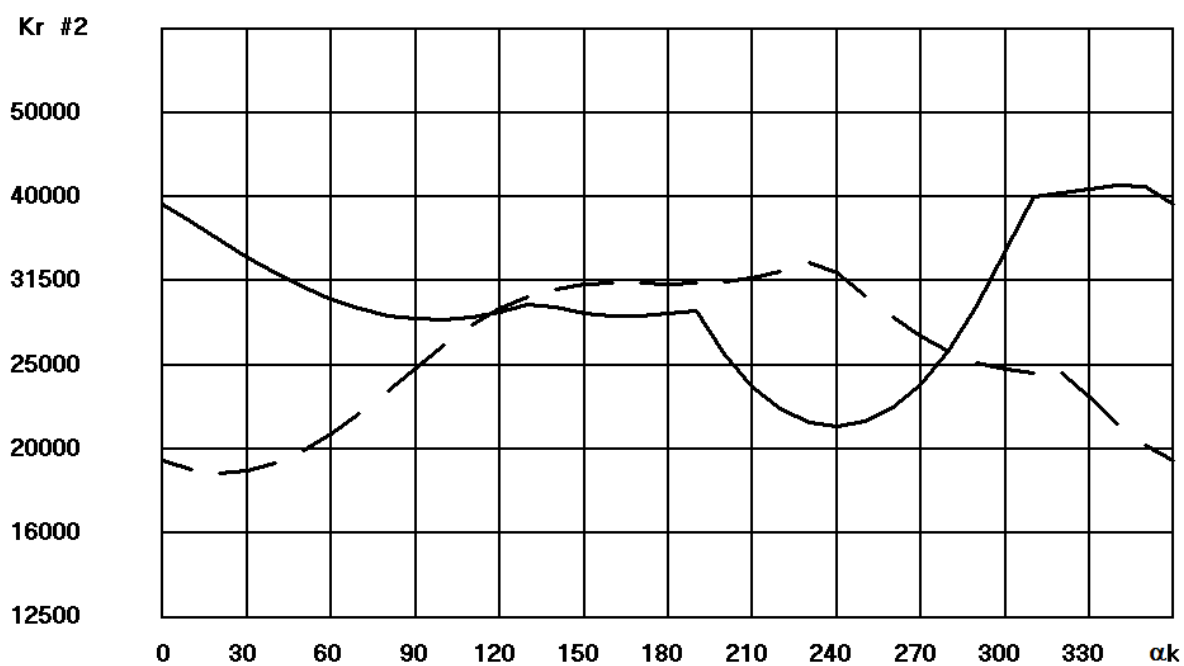

Durata minima richiesta, ore (minimum required life, hours): 10000

Output shaft $\varnothing 110$