

Trommelmotor / Drum Motor Typ TM 216 Standard

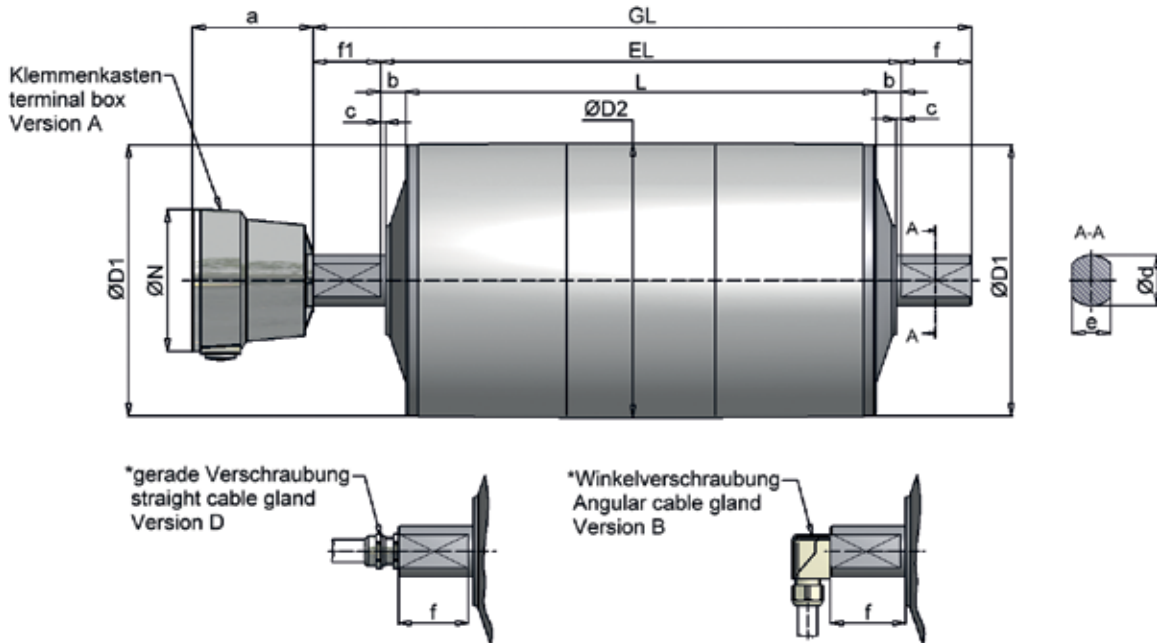

Umlenktrommel / Guide Drum Motor Typ UT 216 Standard

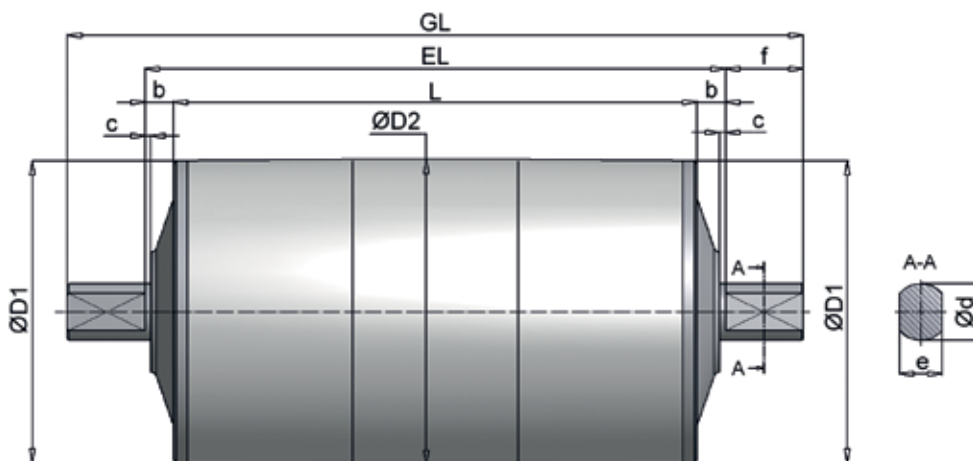

alle Maße in mm / dimensions in mm

TROMMELMOTOR / DRUM MOTOR											STANDARD IP65	OPTIONAL IP66	OPTIONAL IP67			
Größe / size	Typ	ØD1	ØD2**	a	ØN	c	Ød	e	f	f1	b	EL	b	EL	b	EL
216	TM 216.0	213,5	216	95	112	3	40	30	45	45			20	L + 40	auf Anfrage / on request	
216	TM 216.1	213,5	216			3	40	30	55	55	20	L + 40	20	L + 40	37	L + 74
UMLENKTROMMEL / GUIDE DRUM																
216	UT 216.0	213,5	216			3	40	30	45				20	L + 40	auf Anfrage / on request	
216	UT 216.1	213,5	216			3	40	30	55		20	L + 40	20	L + 40	37	L + 74

* mit 1m Kabel / with 1m cable

** Durchmesser bei zylindrischem Trommelkörper / diameter with cylindrical drum design



Leistungsdaten / Performance data Typ TM216.0 - TM216.1

TYP	LEISTUNG / POWER	GESCHWINDIG- KEIT / BELT SPEED	DREHZAHL / ROTATION SPEED	BANDZUG- KRAFT / BELT PULL	TROMMEL MOMENT / TORQUE	STROMAUF- NAHME BEI / POWER INPUT AT 400V / 50Hz	TROMMEL- LÄNGE / DRUM LENGTH L min.	GEWICHT / WEIGHT
	P2	v	n2	F	T2			L=500mm
	[kW]	[m/s]	[1/min]	[N]	[Nm]	[A]	[mm]	[kg]
TM216.0	0,37 8-polig	0,25	22	1460	158	1,50	400	50
		0,31	27	1202	130			
		0,37	33	1005	108			
		0,44	39	849	92			
		0,51	45	723	78			
		0,60	53	619	67			
		0,71	63	521	56			
		0,86	76	429	46			
		1,03	91	359	39			
		1,22	108	303	33			
TM216.0	0,75 6-polig	0,33	29	2251	243	2,20	400	50
		0,40	36	1854	200			
		0,48	43	1549	167			
		0,57	51	1309	141			
		0,67	59	1115	120			
		0,79	69	954	103			
		0,93	82	804	87			
		1,13	100	662	71			
		1,36	120	553	60			
		1,60	142	468	51			
TM216.1	1,50 4-polig	0,33	29	4604	497	3,20	420	57,0
		0,37	33	4016	434			
		0,48	42	3134	338			
		0,60	53	2504	270			
		0,86	76	1749	189			55,0
		1,17	104	1279	138			
		1,34	119	1116	120			
		1,72	152	871	94			
2,16	191	696	75					
TM216.1	2,20 4-polig	0,47	42	4679	505	4,80	420	59,0
		0,59	52	3738	404			
		0,84	75	2610	282			
		1,15	102	1909	206			57,0
		1,32	117	1665	180			
		1,69	150	1300	140			
TM216.1	3,00 4-polig	0,85	75	3547	383	6,60	450	59,0
		1,16	102	2594	280			57,0
		1,33	117	2263	244			
		1,70	150	1766	191			
		2,13	188	1411	152			

Leistungsdaten / performance data Typ TM216.0 - TM216.1

- abweichende Leistungsdaten und Geschwindigkeiten auf Anfrage
- Gewichtsangabe inkl. Ölfüllung (betriebsbereit)
- Mehrgewicht: ca. 5kg auf 100mm Mehrlänge
- bei Bremsanbau erhöht sich das L min. Maß um 100mm

**Normbreiten [L] : 400, 420, 450, 500 ... 1350mm,
ab 1350mm verstärkte Ausführung**

- alternative performance data and speeds on request
- indication of weight incl. oil filling (ready for operating)
- additional weight: approx. 5kg for 100mm add. length
- with brake mounting L min. dimension raises up 100mm

**norm width [L] : 400, 420, 450, 500 ... 1350mm,
from 1350mm reinforced construction**





Ausführungsarten und Optionen / Design types and options

STANDARDAUSFÜHRUNG

- ballig gedrehter Stahlmantel, stahlblank, mit Rostschutz überzogen
- Lagerenddeckel aus Grauguss
- Einspannzapfen aus Stahl, mit Rostschutz überzogen
- Stirnradgetriebe in Stahlverzahnung (geräuscharm)
- Klemmenkasten
- Farbe RAL 2004

STANDARD CONFIGURATION

- crowned shell, mild steel with rust protection paint
- bearing covers made of cast iron
- shafts made of mild steel with rust protection paint
- helical gear unit with steel toothing (quiet)
- terminal box
- color RAL 2004

OPTIONEN

- innenliegende Bremse
- Winkelverschraubung (mit 1m Kabel)
- Gerade Verschraubung (inkl. 1m Kabel)
- Rücklaufsperrung (Kugellagerfreilauf)
- Kettenrad / Zahnriemenscheibe
- Sensorlagereinheit (Drehgeber)
- Trommelkörper zylindrisch, gummiert, verzinkt (kundenspezifisch)
- Edelstahlausführung
- Thermokontakte
- IP67
- geeignet für Frequenzumrichterbetrieb
- Klemmenkastenausführung in Edelstahl
- vertikaler Einbau möglich (bei Bestellung angeben)
- Lebensmittelöl

Weitere Ausführungen nach Kundenwunsch möglich.

OPTIONS

- internal brake
- angular cable gland (with 1m cable)
- straight cable gland with 1m cable
- backstop
- sprocket / toothed belt disc
- sensor bearing unit (rotary encoder)
- cylindrical drum shell, coated, zinc plated (customised)
- stainless steel design
- thermal contact
- IP67
- suitable for frequency converter use
- terminal box design in stainless steel
- vertical mounting (should be stated in the order)
- food-safe lubricant

Other designs on customer request possible.

Einspannlager für HIMMEL® - Trommelmotor / Umlenktrommel Typ 216 Clamping bearing for HIMMEL® - Drum Motor / Guide Drum type 216

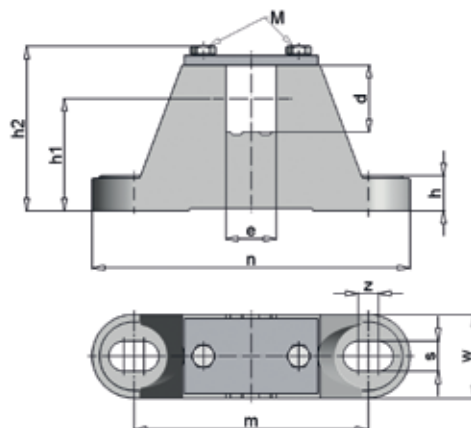

alle Maße in mm / dimensions in mm

TROMMELTYP / DRUM TYPE	EINSPANNLAGER / CLAMPING BEARING	d	e	h	h1	h2	m	n	s	w	z	M	MATERIAL / MATERIAL	ca. kg
TM/UT 216.0	EL40/30 A	40	30	20	47	76	110	160	14	40	10	M8	Gusseisen / Cast iron	1,5
TM/UT 216.1	EL40/30 B	40	30	21	67	102,5	140	190	18	50	12	M8		2,8